

GP grade

Standard type with small dimensions

Construction

- Charge-discharge proof, polar
- Aluminum case with insulating sleeve
- Negative pole connected to case
- Axial leads, welded to ensure perfect electrical contact

Features

- Standard type with small dimensions
- Operation at temperatures up to 105 °C¹⁾
- Good electrical characteristics
- High ripple current capability

Applications

- For general-purpose applications in entertainment electronics
- Semi-professional to professional application range
- For filtering, coupling and pulse circuits

Tape packaging

Capacitors with $d \leq 16$ mm are also available on tape.

Refer to [page 420](#) for information on tapes and examples on how to order them.

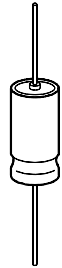

KAL0277-Z

Specifications and characteristics in brief

Rated voltage U_R	6,3 to 100 V-	
Surge voltage U_S	$1,15 \cdot U_R$	
Rated capacitance C_R	4,7 to 10 000 μ F	
Capacitance tolerance	- 10/+ 50 % \cong T	
Useful life	$d \leq 10$ mm	$d \geq 12$ mm
40 °C, U_R	> 200 000 h ($I_{-R,85^\circ C}$)	> 200 000 h ($1,4 \cdot I_{-R,85^\circ C}$)
85 °C, U_R ; I_{-max}	> 3 000 h	> 4 000 h
Failure percentage	≤ 1 % (during useful life)	
Failure rate (1 fit = $1 \cdot 10^{-9}$ /h)	$d \leq 10$ mm: ≤ 100 fit $d \geq 12$ mm: ≤ 40 fit	
Voltage endurance test	2 000 h, 85 °C (at U_R)	
Leakage current I_{lka} (5 min, 20 °C)	$I_{lka} \leq 0,3 \mu A \cdot \left(\frac{C_R}{\mu F} \cdot \frac{U_R}{V} \right)^{0,7} + 4 \mu A$	

1) Operation at 105 °C and 0,6 $I_{-max,85^\circ C}$ permissible for a total of 500 h.



Specifications and characteristics in brief

Self-inductance L_{ESL}	d (mm)	6,5	8,5	10	12	14	16	18	21	25
	l (mm)	15,5	15,5	25	30	30	30	39,5	40	40
	L_{ESL} approx. (nH)	14	17	35	37	38	45	57	30	34
IEC climatic category	in accordance with IEC 68-1 40/085/56 (−40 °C/+85 °C, 56 days damp heat test)									
Detail specification	similar to CECC 30 301-044									
Sectional specification	IEC 384-4									
Vibration resistance	in accordance with IEC 68-2-6, test Fc: displacement amplitude 0,35 mm, frequency range 10 to 55 Hz, acceleration max. 5 g, duration 3 × 2 h									

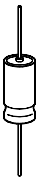

B 41 010
B 41 283

Dimensional drawing

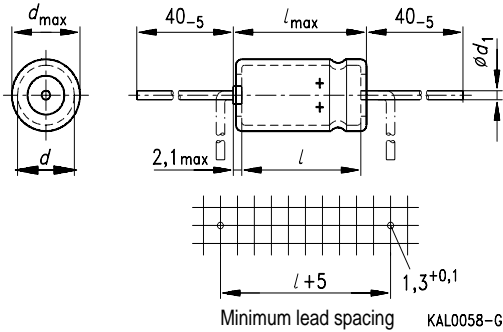

Type	Dimensions (mm)		Lead wire diameter d_1	Approximate weight (g)
	$d \times l$	$d_{\max} \times l_{\max}$		
B 41 283	6,5 × 15,5	7 × 17	0,6	1,1
	8,5 × 15,5	9 × 17		1,8
	10 × 25	10,5 × 26,5		3,2
B 41 010	12 × 30	12,5 × 32	0,8	5,4
	14 × 30	14,5 × 32		7,5
	16 × 30	16,5 × 32		9,3
	18 × 39,5	18,5 × 40,3		14
	21 × 40	21,5 × 41,5		18
	25 × 40	25,5 × 41,5		26

Packing units

Case dimensions $d \times l$ (mm)	Bulk PU (pcs.)	Reel packing PU (pcs./reel)
6,5 × 15,5	2000	1300
8,5 × 15,5	1500	1000
10 × 25	900	600
12 × 30	600	450
14 × 30	400	350
16 × 30	350	250
18 × 39,5	250	—
21 × 40	200	—
25 × 40	150	—

Not for new design. For new design see types B 41 682, [page 365](#)



Overview of available types

U_R (V-)	6,3	10	16	25	40	63	100
C_R (μ F)	Case dimensions $d \times l$ (mm)						
4,7							6,5 × 15,5
10						6,5 × 15,5	8,5 × 15,5
22					6,5 × 15,5	8,5 × 15,5	8,5 × 15,5
47				6,5 × 15,5	8,5 × 15,5	8,5 × 15,5	10 × 25
100		6,5 × 15,5	8,5 × 15,5	8,5 × 15,5	10 × 25	10 × 25	12 × 30
220		8,5 × 15,5	8,5 × 15,5	10 × 25	10 × 25	12 × 30	16 × 30
470	8,5 × 15,5	10 × 25	10 × 25	12 × 30	12 × 30	16 × 30	21 × 40
1 000	10 × 25	12 × 30	12 × 30	14 × 30	16 × 30	21 × 40	
2 200	12 × 30	14 × 30	16 × 30	18 × 39,5	21 × 40		
4 700	16 × 30	18 × 39,5	21 × 40	25 × 40			
10 000		25 × 40					

The above capacitance and voltage ratings are available in different cases upon request. Other voltage and capacitance ratings are also available upon request.

Not for new design. For new design see type B 41 682, [page 365](#)

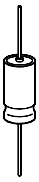

B 41 010
B 41 283

Technical data and ordering codes

U_R	C_R	Case dimensions $d \times l$ mm	$R_{ESR, typ}$ 100 Hz 20 °C Ω	$R_{ESR, max}$ 100 Hz 20 °C Ω	Z_{max} 10 kHz 20 °C Ω	I_{-max} 100 Hz 40 °C A	I_{-R} 100 Hz 85 °C A	Ordering code ¹⁾ Short code
B41010- ($d \geq 12$ mm), B41283- ($d \leq 10$ mm)								
6,3	470	8,5 × 15,5	0,44	0,75	0,46	0,73	0,25	-D2477-T90
	1 000	10 × 25	0,24	0,35	0,22	1,2	0,42	-B2108-T90
	2 200	12 × 30	0,12	0,19	0,10	2,1	0,71	-B2228-T
	4 700	16 × 30	0,08	0,11	0,05	3,2	1,1	-E2478-T
10	100	6,5 × 15,5	1,5	3,5	1,7	0,35	0,12	-C3107-T90
	220	8,5 × 15,5	0,65	1,4	0,79	0,61	0,21	-D3227-T90
	470	10 × 25	0,32	0,68	0,37	1,0	0,36	-B3477-T90
	1 000	12 × 30	0,18	0,32	0,16	1,7	0,57	-A3108-T
	2 200	14 × 30	0,19	0,18	0,08	2,3	0,81	-C3228-T
	4 700	18 × 39,5	0,06	0,10	0,05	4,1	1,4	-C3478-T
	10 000	25 × 40	0,05	0,07	0,05	5,5	1,9	-C3109-T
16	100	8,5 × 15,5	1,3	2,8	1,4	0,41	0,14	-C4107-T90
	220	8,5 × 15,5	0,58	1,3	0,65	0,61	0,21	-C4227-T90
	470	10 × 25	0,27	0,60	0,30	1,1	0,39	-B4477-T90
	1 000	12 × 30	0,15	0,28	0,13	1,8	0,63	-B4108-T
	2 200	16 × 30	0,09	0,16	0,06	2,7	0,93	-E4228-T
	4 700	21 × 40	0,06	0,09	0,05	4,4	1,5	-C4478-T
25	47	6,5 × 15,5	2,4	5,3	2,1	0,26	0,09	-C5476-T90
	100	8,5 × 15,5	1,0	2,5	1,0	0,46	0,16	-C5107-T90
	220	10 × 25	0,44	1,1	0,45	0,81	0,28	-C5227-T90
	470	12 × 30	0,21	0,53	0,19	1,5	0,53	-B5477-T
	1 000	14 × 30	0,12	0,25	0,09	2,1	0,74	-C5108-T
	2 200	18 × 39,5	0,07	0,14	0,05	3,8	1,3	-C5228-T
	4 700	25 × 40	0,05	0,09	0,05	5,2	1,8	-C5478-T

Not for new design. For new design see type B 41 682, [page 365](#)

1) To obtain the required ordering code, prefix the type number to the short code. E. g.: B41283-D2477-T90
B41283-... ($d \leq 10$ mm)
B41010-... ($d \geq 12$ mm)



Technical data and ordering codes

U_R	C_R	Case dimensions $d \times l$ mm	$R_{ESR, typ}$ 100 Hz 20 °C Ω	$R_{ESR, max}$ 100 Hz 20 °C Ω	Z_{max} 10 kHz 20 °C Ω	I_{-max} 100 Hz 40 °C A	I_{-R} 100 Hz 85 °C A	Ordering code ¹⁾ Short code
B41010- ($d \geq 12$ mm), B41283- ($d \leq 10$ mm)								
40	22	6,5 × 15,5	4,0	8,0	3,6	0,20	0,07	-C7226-T90
	47	8,5 × 15,5	1,5	3,8	1,7	0,38	0,13	-E7476-T90
	100	10 × 25	0,70	1,8	0,80	0,64	0,22	-C7107-T90
	220	10 × 25	0,36	0,80	0,36	0,96	0,33	-B7227-T90
	470	12 × 30	0,18	0,38	0,15	1,7	0,57	-B7477-T
	1 000	16 × 30	0,10	0,18	0,08	2,6	0,88	-E7108-T
	2 200	21 × 40	0,07	0,11	0,05	4,1	1,4	-C7228-T
	63	10	6,5 × 15,5	5,0	13	6,0	0,17	0,06
22		8,5 × 15,5	2,5	6,3	2,7	0,29	0,10	-D8226-T90
47		8,5 × 15,5	1,2	3,0	1,2	0,44	0,15	-D8476-T90
100		10 × 25	0,55	1,4	0,60	0,78	0,27	-B8107-T90
220		12 × 30	0,30	0,64	0,25	1,3	0,44	-B8227-T
470		16 × 30	0,14	0,30	0,12	2,1	0,74	-D8477-T
1 000		21 × 40	0,08	0,14	0,06	3,8	1,3	-B8108-T
100		4,7	6,5 × 15,5	9,5	24	10	0,15	0,05
	10	8,5 × 15,5	4,0	10	5,0	0,23	0,08	-L9106-T90
	22	8,5 × 15,5	1,8	4,5	2,2	0,35	0,12	-D9226-T90
	47	10 × 25	0,85	2,1	1,0	0,64	0,22	-B9476-T90
	100	12 × 30	0,40	1,0	0,45	1,1	0,38	-B9107-T
	220	16 × 30	0,22	0,55	0,20	1,7	0,59	-E9227-T
	470	21 × 40	0,12	0,26	0,10	2,9	1,0	-B9477-T

Not for new design. For new design see type B 41 682, [page 365](#)

1) To obtain the required ordering code, prefix the type number to the short code. E. g.: B41283-C7226-T90
B41283-... ($d \leq 10$ mm)
B41010-... ($d \geq 12$ mm)

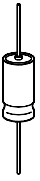

B 41 010
B 41 283

Useful life

versus ambient temperature T_A under ripple current operating conditions¹⁾

B 41 283 ($d \leq 10$ mm)

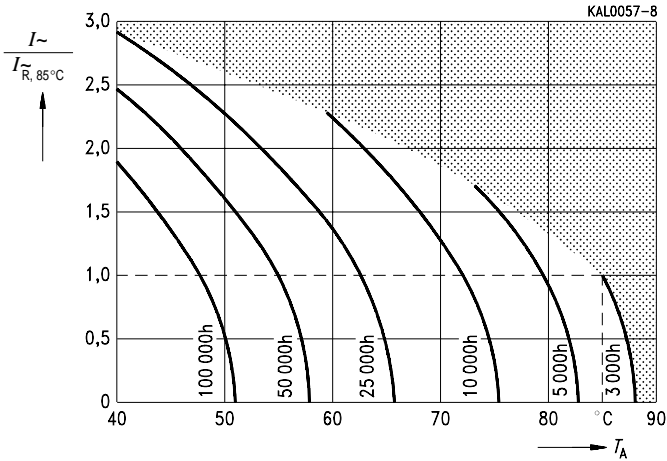

B 41 010 ($d \geq 12$ mm)

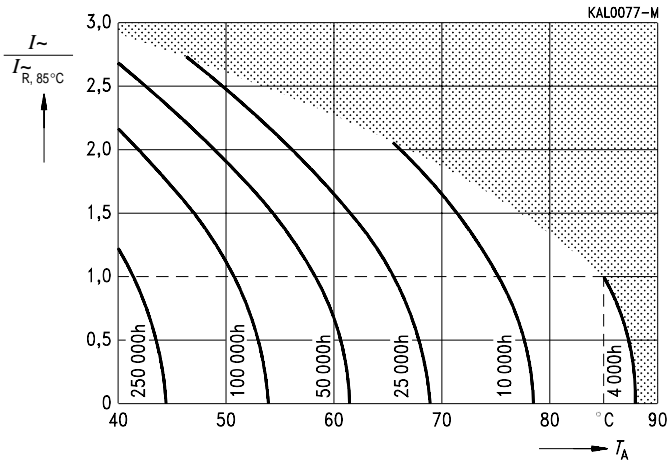

1) Refer to [page 34](#) for an explanation on how to interpret the useful life graphs.

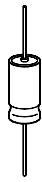

Permissible ripple current I_f
versus frequency f

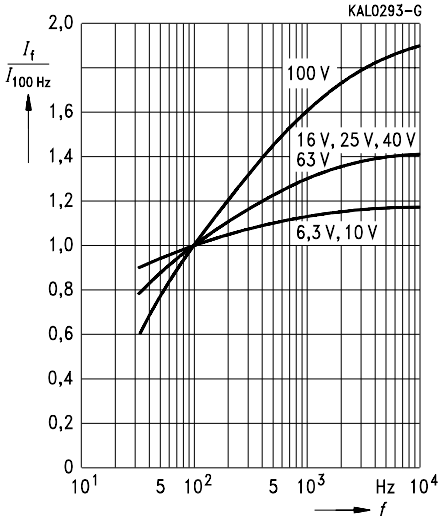

Series capacitance C_s at $f = 100$ Hz
versus temperature T
Typical behavior

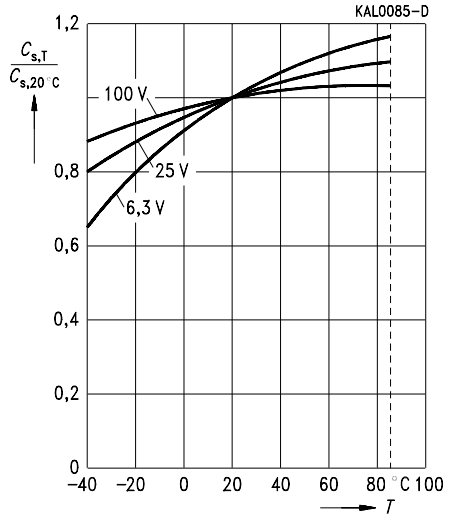

Equivalent series resistance R_{ESR}
at $f = 100$ Hz
versus temperature T
Typical behavior

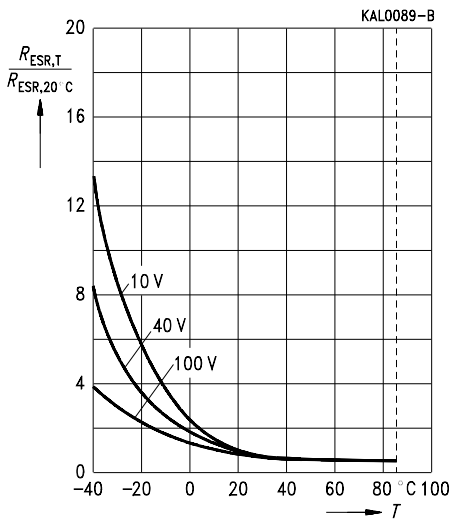

Impedance Z
at $f = 10$ kHz
versus temperature T
Typical behavior

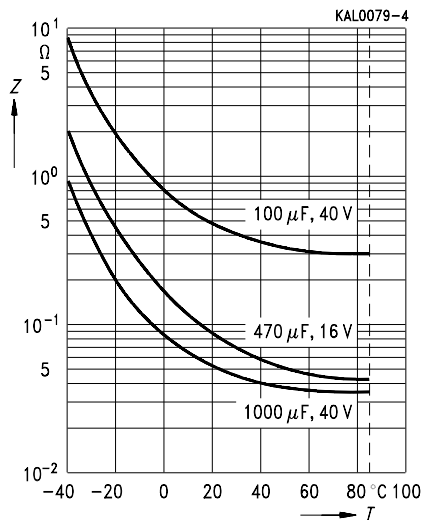

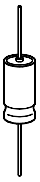

B 41 010
B 41 283

Impedance Z

versus frequency f
and temperature T for 470 $\mu\text{F}/16\text{ V}$ —
Typical behavior

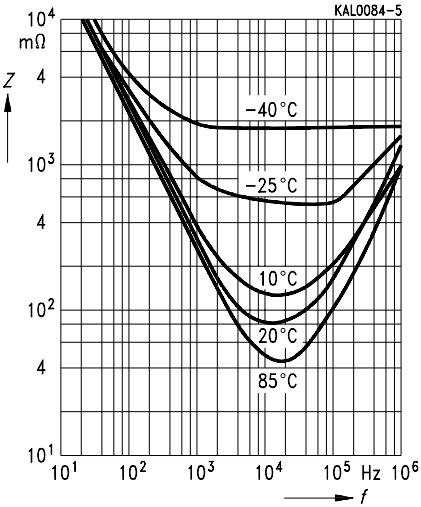

Impedance Z

versus frequency f
and temperature T for 1000 $\mu\text{F}/40\text{ V}$ —
Typical behavior

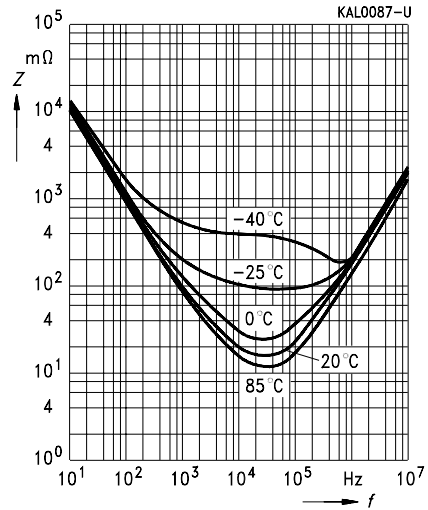

Impedance Z

versus frequency f
Typical values at 20 °C
 $U_R \leq 100\text{ V}$ —

